



<https://pleaa.org>

When PLEAA re-signed the Shoshone Trail system it became clear, in a hurry:

- we needed a way to carry tools, equipment, and materials for the job onto the trail
- a conventional trailer worked, but not very well - on one outing we scattered carsonite posts over miles of trail
- whatever we developed needed to be able to navigate narrow and rough trails and terrain
- it would make more sense if the trailers COULD be used for other trail projects

As ideas evolved, we also realized the project would take more funding than we had available. The trailers you see below are the result of this process and funding largely by a FIG Grant. [[click here for FIG grant info](#)]

PLEAA Board member Chris Reed designed and built these trailers specifically for trail signing. They can carry tools for almost any trail maintenance along almost any trail. For further information and details [contact Chris here](#).





The Redi-driver box, Carsonite Storage Tube and Tiedowns

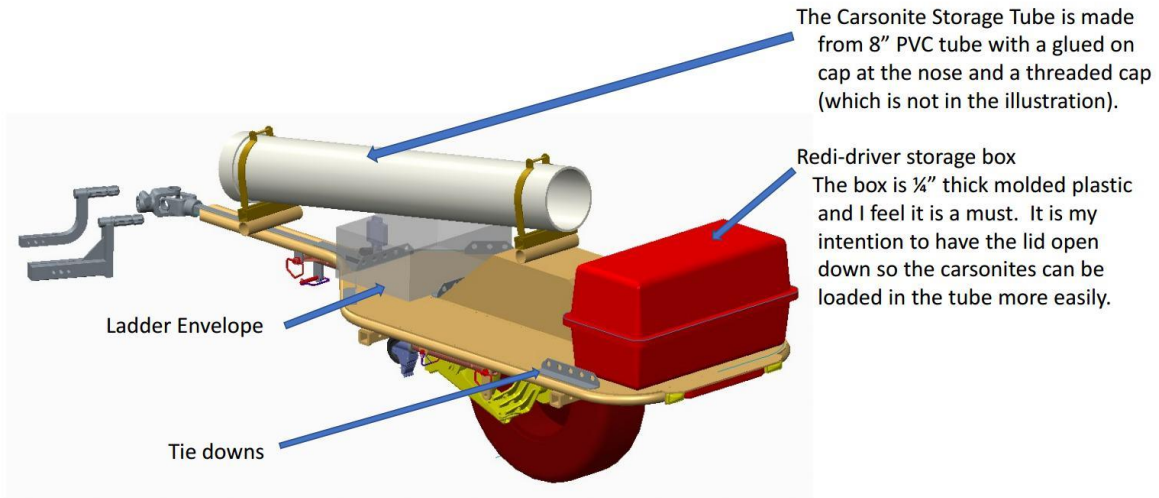

The DeWalt Tool Boxes

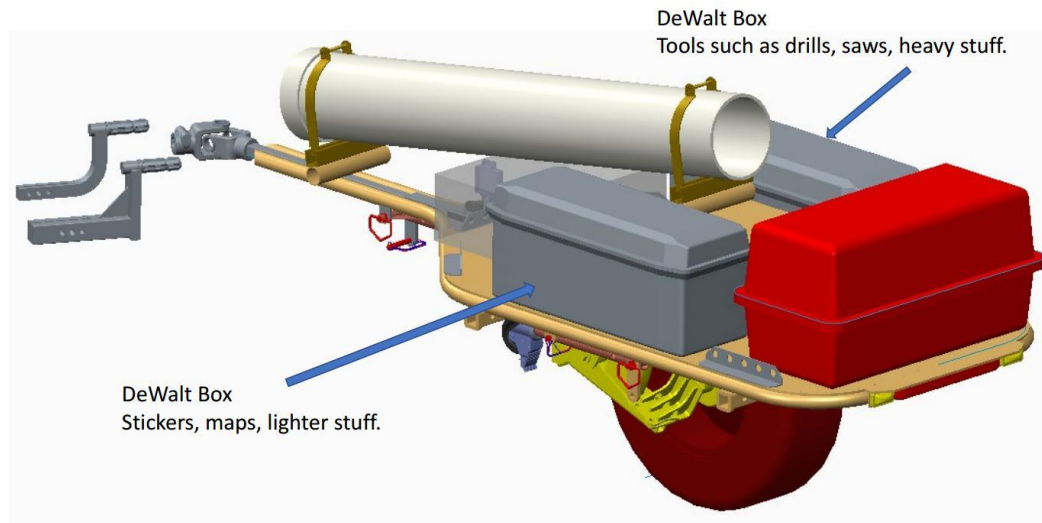

PLEAA Signing and Work Trailer

Design Criteria:

Works with 2" & 1-1/4" receivers

Highly maneuverable

Carries all signage tools

Fits 50" trails

Light

**Concept works:
click link**

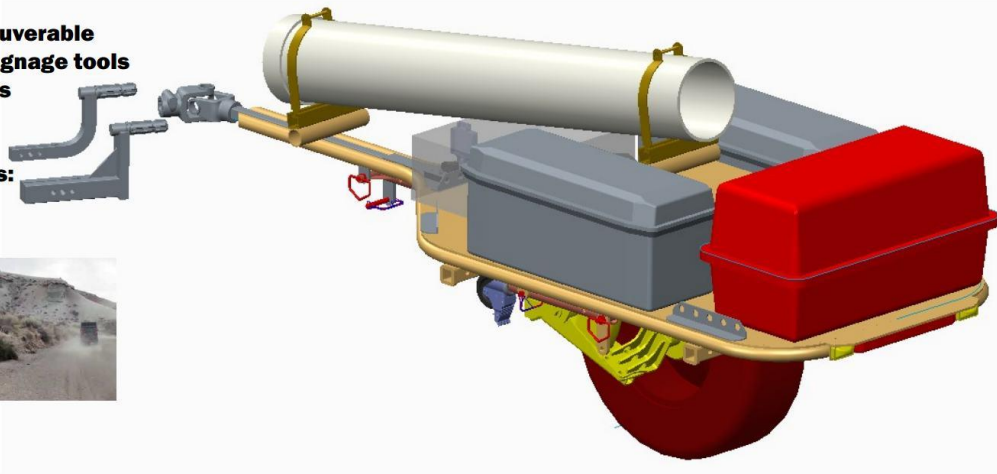

PLEAA Signing and Work Trailer



The prototype worked even better than expected.